

# NX Hipot

## NX Hipot Testers Feature Summary and Specifications



**NX Hipot**  
64 - 128 test points



**NX Hipot +**  
64 - 1024 test points

Low Voltage	
Connections	Continuity: 1 Ω - 100 Ω (±1 Ω), 100 Ω - 500 KΩ (±1 Ω, ±1%), 500 KΩ - 2 MΩ (±5%) Shorts: 1 KΩ - 2 MΩ (± 20%)
Components	Diodes: Checks for proper orientation Resistors: 1 Ω - 100 Ω (±1 Ω), 100 Ω - 500 KΩ (±1 Ω, ±1%), 500 KΩ - 2 MΩ (±5%) Capacitors: 100pF to 500uF (± 5% to 20% based on capacitor type, ±10pF)
4-wire mode	.005 Ω - 100 Ω (± .005 Ω, ± 1%)
Relay Testing	Capable of active relay testing
Test Voltage	14 VDC maximum (Automatically selected by the NX Tester)
Test Current	5mA DC maximum
Test Speed	1 second per 1024 test points (continuity only) 3 seconds per 1024 test points (continuity and shorts)
High Voltage	
Hipot Range	50 - 1500VDC 50 - 1000VAC
Insulation Resistance Range	5 MΩ - 1 GΩ (± 10%)
Hipot Duration	.010 - 120 seconds per connection group
General	
Display	Easy to read 4-line x 20 character display
Audible Tones	Variety of user programmable tones for error notification and special events
Program Storage	1.3MB with no file quantity limitation
Control Ports	24 control port capability (additional hardware required)
Serial Ports	Two RS-232 ports (optional two additional RS-232 ports)
Test Point Interface	DIN 41612 (96 Position, 32 Loaded)
Input Power	100 - 240VAC, 50 - 60Hz external power supply (30W Hipot, 60W Hipot+) Power supply provides 15VDC to the NX Tester
Test Point Capacity	NX Hipot: 64 - 128 test points NX Hipot+: 64 - 1024 test points
Size (W x D x H)	NX Hipot: 10.7" x 7.5" x 3.8" (27.2 cm x 19.0 cm x 9.7 cm) NX Hipot+ Display Unit: 10.7" x 2" x 3.8" (27.2 cm x 5.1 cm x 9.7 cm) NX Hipot+ Base Unit: 9.5" x 6.4" x 8.6" (24.2 cm x 16.3 cm x 21.9 cm) NX Hipot+ Expansion Unit: 9.5" x 6.4" x 6.1" (24.2 cm x 16.3 cm x 15.5 cm)
Weight	NX Hipot: 7.4 lbs (3.4 Kg) NX Hipot+ Display Unit: 2.5 lbs (1.2 Kg) NX Hipot+ Base Unit: 13.8 lbs (6.3 Kg) NX Hipot+ Expansion Unit: 9.8 lbs (4.5 Kg)
Operating Temperature	32 - 122 degrees F (0 - 50 degrees Celsius)
Warranty	One year parts and labor

**Dynalab**  
TEST SYSTEMS

Dynalab Test Systems, Inc.  
555 Lancaster Avenue  
Reynoldsburg, OH  
43068, USA

614-729-6550  
800-SOS-DYNA (USA & Canada)

www.DynalabTesters.com

© Copyright, 2010, Dynalab Test Systems, Inc. All rights reserved.  
All features/functions mentioned within are subject to change. This document is for informational purposes only. Dynalab Test Systems, Inc., makes no warranties, expressed or implied, in this document. Dynalab® and NX® are trademarks of Dynalab Test Systems, Inc.



## Hipot Testers

NX Hipot Testers are fast, accurate, and easy to use. Dynalab designed NX Hipot Testers using the latest available technologies to provide a flexible and adaptable product line that meets the changing needs of wire harness manufacturers. NX Hipot Testers provide all the features of Dynalab's low voltage NX Testers, plus the additional capability of high voltage testing for insulation resistance and dielectric withstand. For test applications that span the range from simple to complex, Dynalab's NX Hipot Testers offer more features than the competition at a lower price.

Dynalab Testers are used by the world's largest automotive and appliance wire harness manufacturers. With over 20 years of industry-leading experience and with more than 20,000 testers sold, Dynalab has firmly established a reputation of excellence in quality, capability and service.

**Dynalab**  
TEST SYSTEMS

**Stand-alone operation - no PC required**

# NX Hipot

## Complete Electrical Test

- Wires - Opens and Shorts
- Diodes - Open, Short, Reverse
- Resistors - 1  $\Omega$  to 2 M $\Omega$
- Capacitors - 100pF to 500uF
- Relays - Active and Passive
- Fixture Detection Switches
- Hipot Range - 50 to 1500VDC
- Insulation Resistance - 5 M $\Omega$  to 1 G $\Omega$
- Hipot Range - 50 to 1500VDC  
50 to 1000VAC

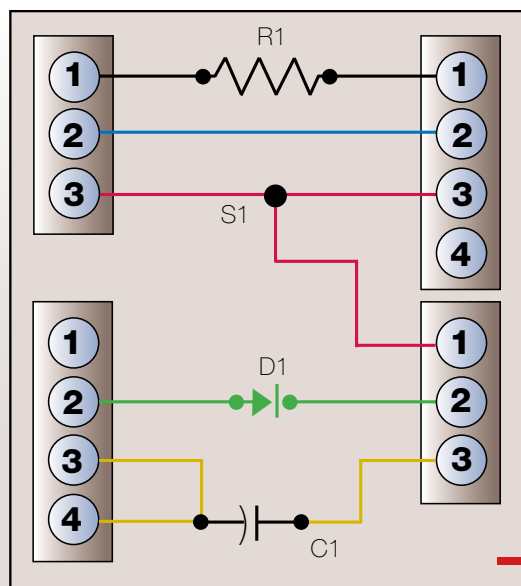

## Print Reports

Track defects or test results, by printing a complete report of every harness tested.



## Print Labels

Identify good harnesses by printing user-specified formatted labels that can contain:

- Part Number and Revision
- Date and Time
- Serial Number
- Operator Name
- And more...



## Control External Devices

- Release Fixture Clamps
- Activate valves, relays, solenoids, etc.
- Illuminate LEDs



## Read Barcodes

- Select programs automatically.
- Read data from harness label or work orders.
- Verify correct part number and validate program name.



## Networking

- Harness production/testing processes can be monitored remotely from any PC.
- Test Programs can be sent remotely to any NX Tester in the plant.
- Thousands of Test Programs can be accessed directly from any NX Tester.
- Production and Quality data can be stored real time in a database.

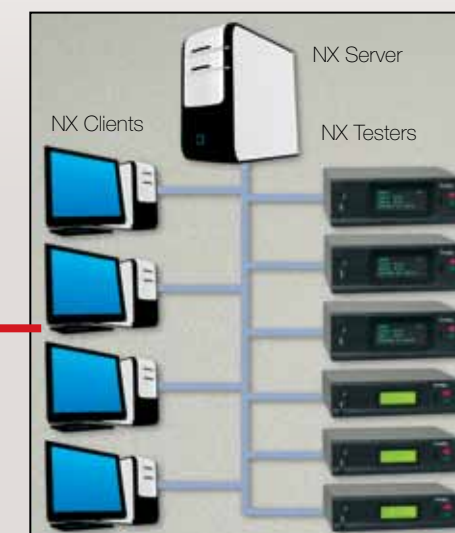

## Store and Transfer Programs

Transfers programs between a computer and a Tester.



## Manage Security

- Restrict access to Tester and Programs.
- Allows only authorized personnel to interrupt a Test.



## Troubleshoot Fixtures

Provides assistance identifying test points, during a test or while troubleshooting test fixtures.

